



FlexGips - Najszybszy system suchej zabudowy

Cz 1:

O firmie

O firmie

Firma istnieje od 1996 roku w branży wykończeń wnętrz pod nazwą INTERSYSTEM.

To ponad 22 lat doświadczeń przy wykończeniach wnętrz na dużych jak i małych inwestycjach.

Jako firma wykończeniowa w latach 1996 - 2018 zrealizowaliśmy ponad 48 wykończeń instytucjonalnych w Polsce i Europie.

Realizowaliśmy również inwestycje z klientami indywidualnymi, na projekt, wykonawstwo apartamentów, domów jednorodzinnych i mieszkań. Ponad 160 różnych realizacji.



Przykładowa realizacja: Teatr Syrena w Warszawie

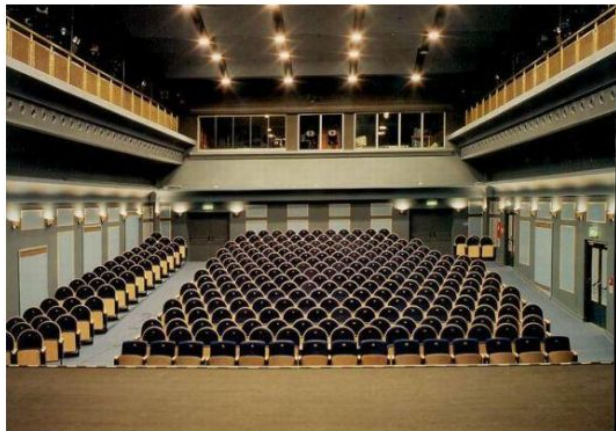

Przykładowa realizacja: Prywatne mieszkanie

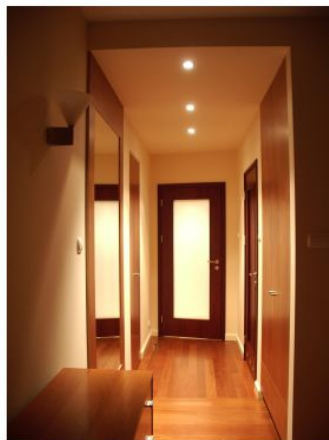

Przykładowa realizacja: Prywatne mieszkanie

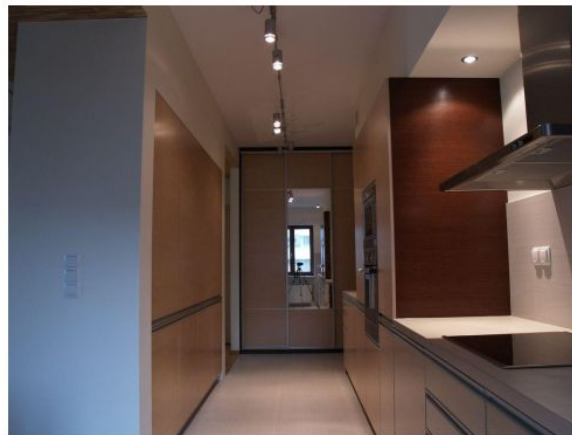

Nagrody

- I miejsce w konkursie BPB
Trophy Poland, 2001r.

- Wyróżnienie w konkursie
BPB INTERNATIONAL Trophy
Vienna, 2002r.



Nagrody

- I miejsce w konkursie „Sztuka Montażu” Polskie Stowarzyszenie Gipsu, 2003r.
- Możliwość współpracy z ASP w Gdańsku przy projekcie wnętrza Polskiego Pawilonu Wystawienniczego. W ramach projektu „Biennale Architektury” w Wenecji, 2006r



O firmie

Od 2015 r. zajmujemy się produkcją gotowych elementów na wymiar i pod projekt z płyt gipsowo-kartonowych oraz produkcją odlewów gipsowych GRG 3D pod nazwą FlexGips.

Jesteśmy Polskim producentem. Produkcja FlexGips odbywa się w Otwocku Wielkim pod Warszawą.

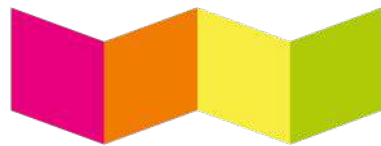

flexgipsTM

od 2015

**PRODUKUJEMY
PREFABRYKATY**



**POLSKI
PRODUKT**

+600

**ZAMÓWIENÍ ONLINE
W 2018 ROKU**



**BEZPŁATNE
DORADZTWO**



**DBAMY
O ŚRODOWISKO**



**SOLIDNY
PARTNER**

Nagrody

- List nominacyjny za realizację projektu pt. „Wdrożenie nowej technologii do produkcji materiałów na bazie płyt gipsowo-kartonowych”

LIST
NOMINACYJNY
2018

POLSKA NAGRODA
INTELIGENTNEGO
ROZWOJU 2018

Z przyjemnością informujemy, że

Intersystem

uzyskał nominację do

Polskiej Nagrody Inteligentnego Rozwoju 2018
pod patronatem Prezes Urzędu Patentowego RP, dr Alicji Adamczak

w kategorii: Innowacje w przemyśle 4.0
za realizację projektu pn. „Wdrożenie nowej technologii do produkcji materiałów
budowlanych na bazie płyt gipsowo-kartonowych”

Tychy, 13.09.2018 r.

 Rzecznik Innowacji

 Rzecznik Inwestycji

 CENTRUM
INTELIGENTNEGO
ROZWOJU

Cz 2:

Co to jest FlexGips?

Co to jest FlexGips?

FlexGips to prefabrykaty z płyt gipsowo-kartonowych. Czyli gotowe, sklejone detale, przygotowane od razu do montażu.



Co to jest FlexGips?

Zamiast tradycyjnej obróbki płyt, narożników i trudnych detali, to element gotowy do przykręcenia.

Tradycyjny sposób



FlexGips

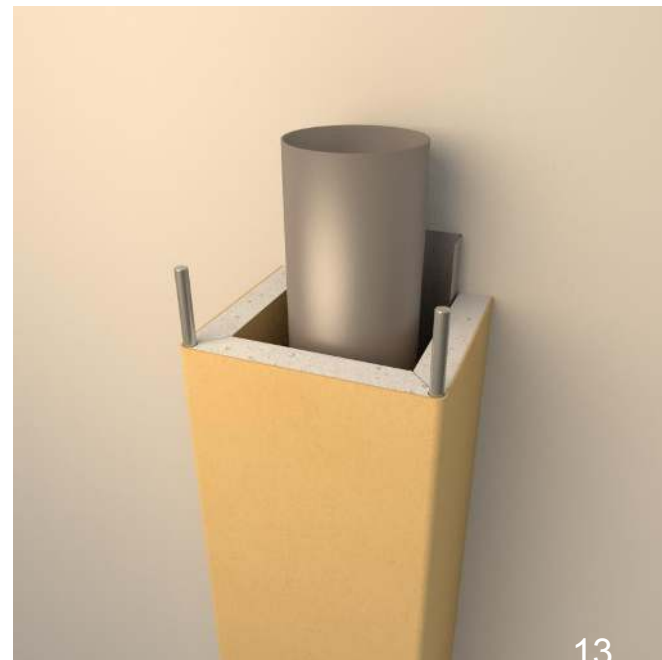

Co to jest FlexGips?

Niezbędne czynności, aby wykonać zabudowę:

Tradycyjny sposób



1. Pomiar i zamówienie palet płyt gk.
2. Transport i rozładunek.
3. Przeniesienie płyt w miejsce wykończenia.
4. Przygotowanie płyt do montażu:
 - pomiar,
 - cięcie,
 - szlifowanie by wygładzić powierzchnię.
6. Montaż płyt do konstrukcji.
7. Montaż nośników.
8. Szpachlowanie wkrętów i łączeń płyt.
9. Szpachlowanie i osadzanie metalowych narożników.
10. "Suszenie zabudowy".
11. Szlifowanie szpachlowanych powierzchni.
12. Punkty od 9 do 11 powtarzanie aż do momentu, kiedy powierzchnie będą równe i gładkie, a narożniki będą wyglądały estetycznie.

FlexGips



1. Pomiar i zamówienie palet formatek GK.
2. Transport i rozładunek.
3. Przeniesienie płyt w miejsce wykończenia.
4. Montaż formatek do konstrukcji.
5. Szpachlowanie wkrętów i łączeń płyt.
6. "Suszenie zabudowy".
7. Szlifowanie szpachlowanych powierzchni.

Co to jest FlexGips?

EFEKT?

Daje to, do 3 razy krótszy montaż w porównaniu do tradycyjnego sposobu.

Czas montażu:

FlexGips

Do 3 razy krócej

Tradycyjny sposób

Normalny czas

Cz 3:

Realizacje i zastosowanie systemu FlexGips

Galeria
Północna -
Pasaż



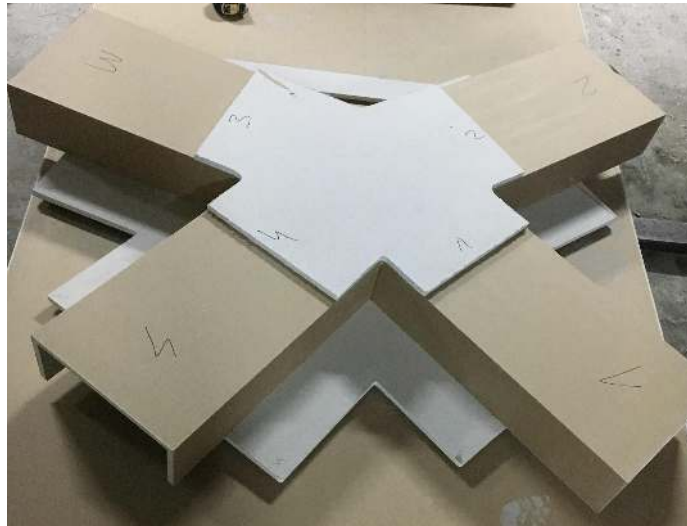
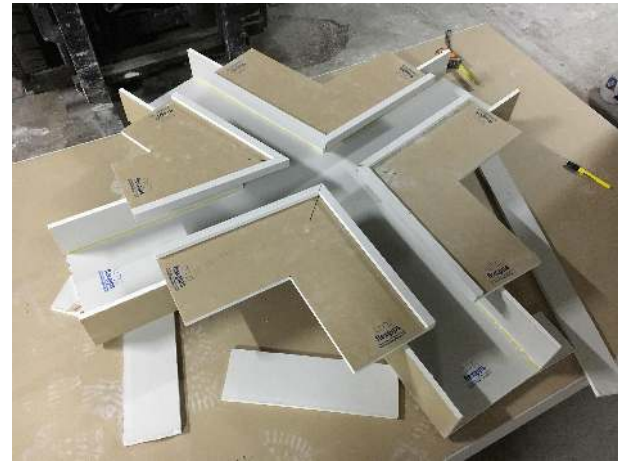
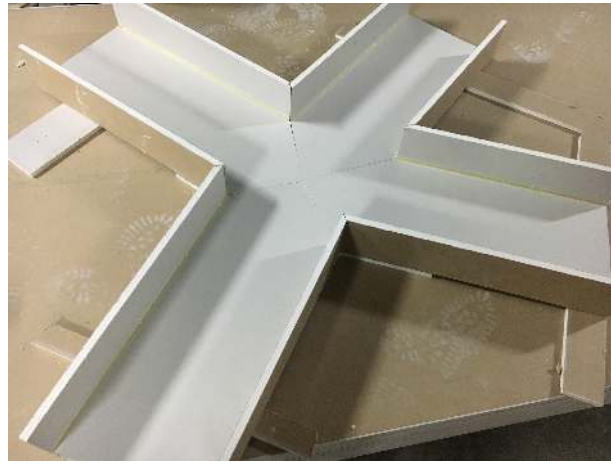
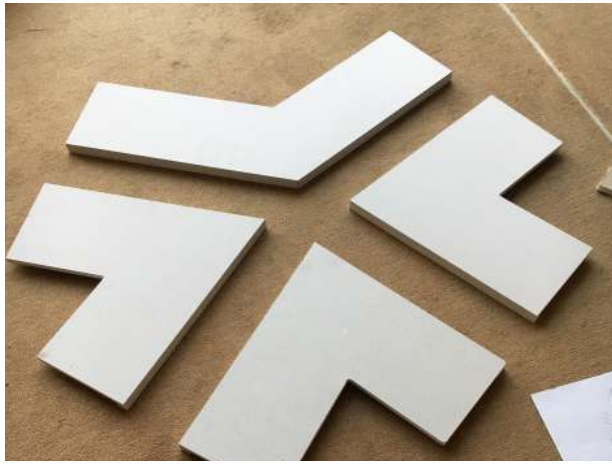



Galeria
Północna -
korytarze, węzły
sanitarne







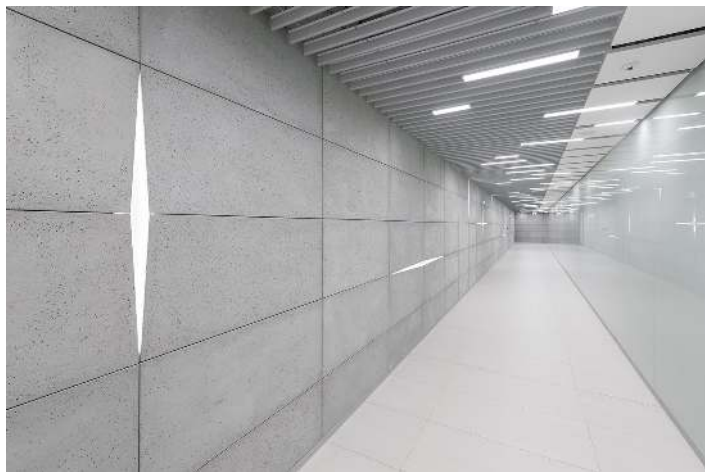

Galeria Forum Gdańsk



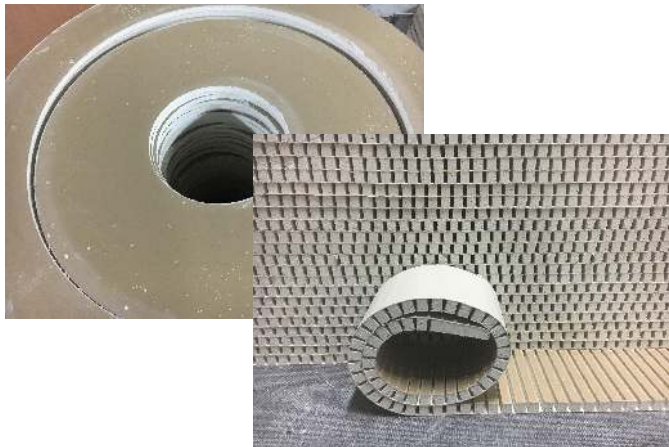
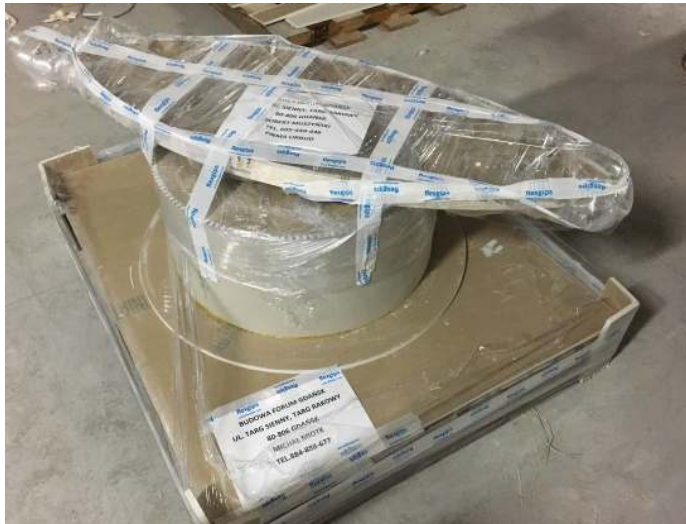
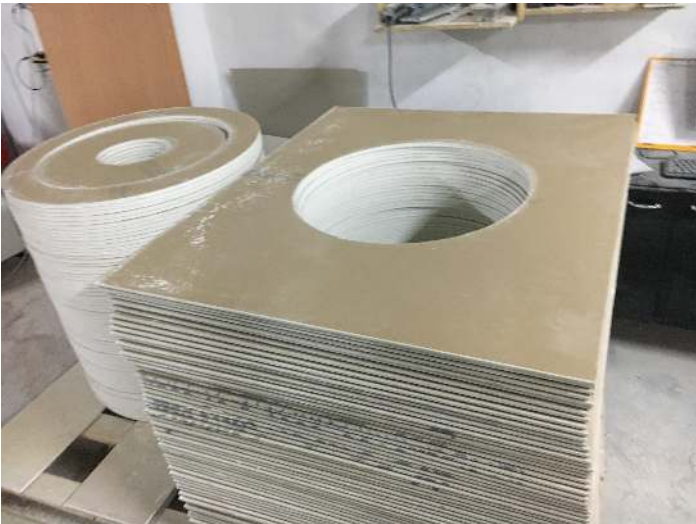



ZARA
Złote Tarasy



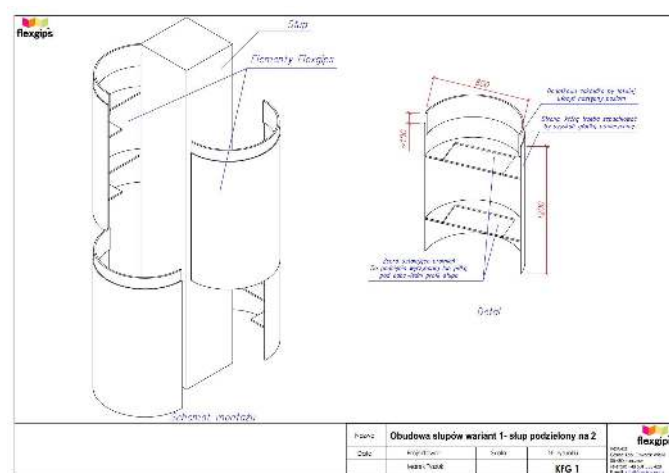
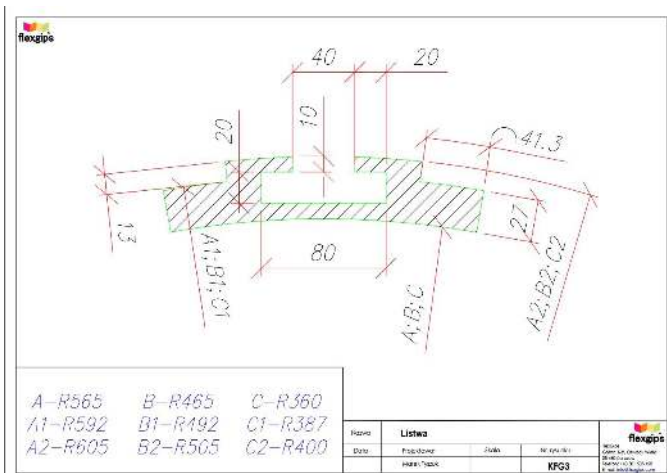
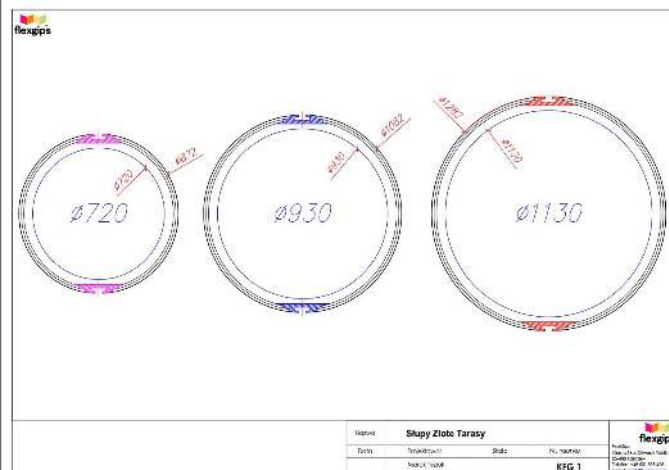
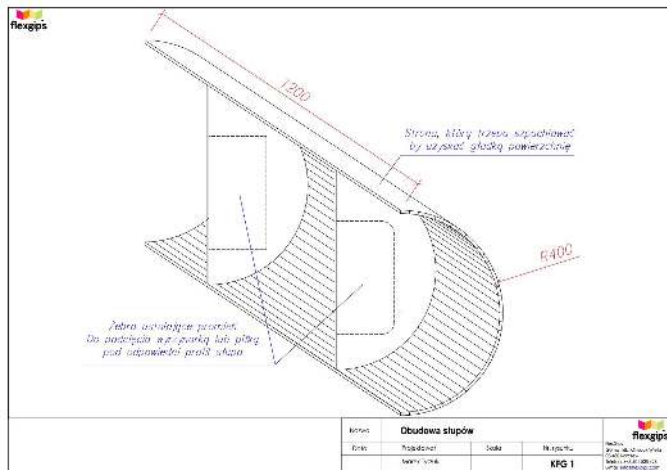

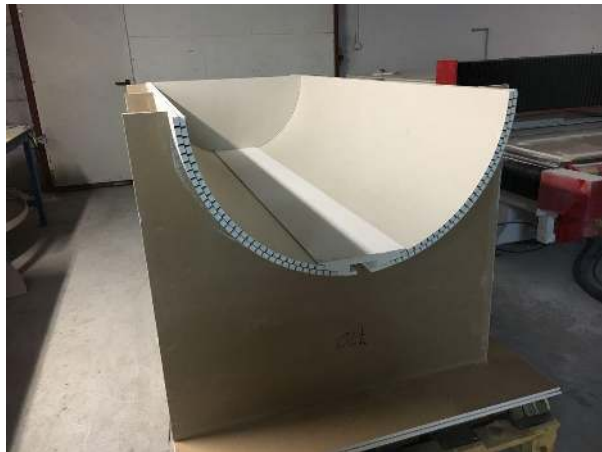





Sklepy Magno



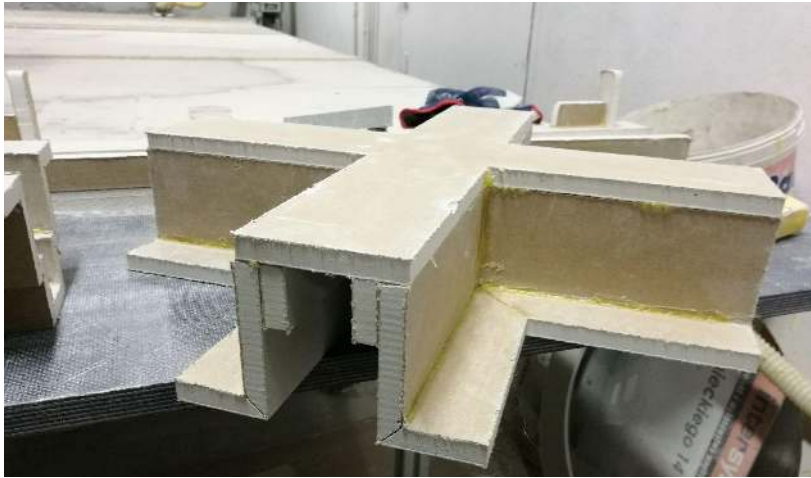





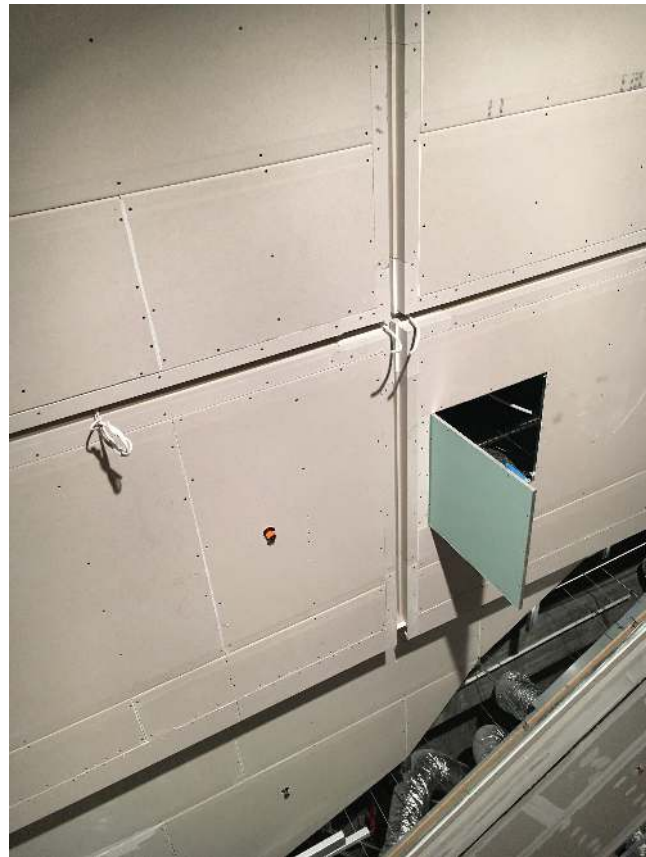

Sklep z
zabawkami -
Hamleys





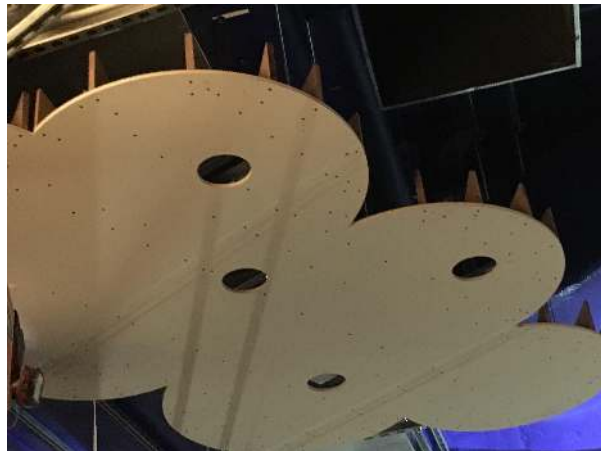



Drukarnia 3D
Warszawa -
Pomieszczenie



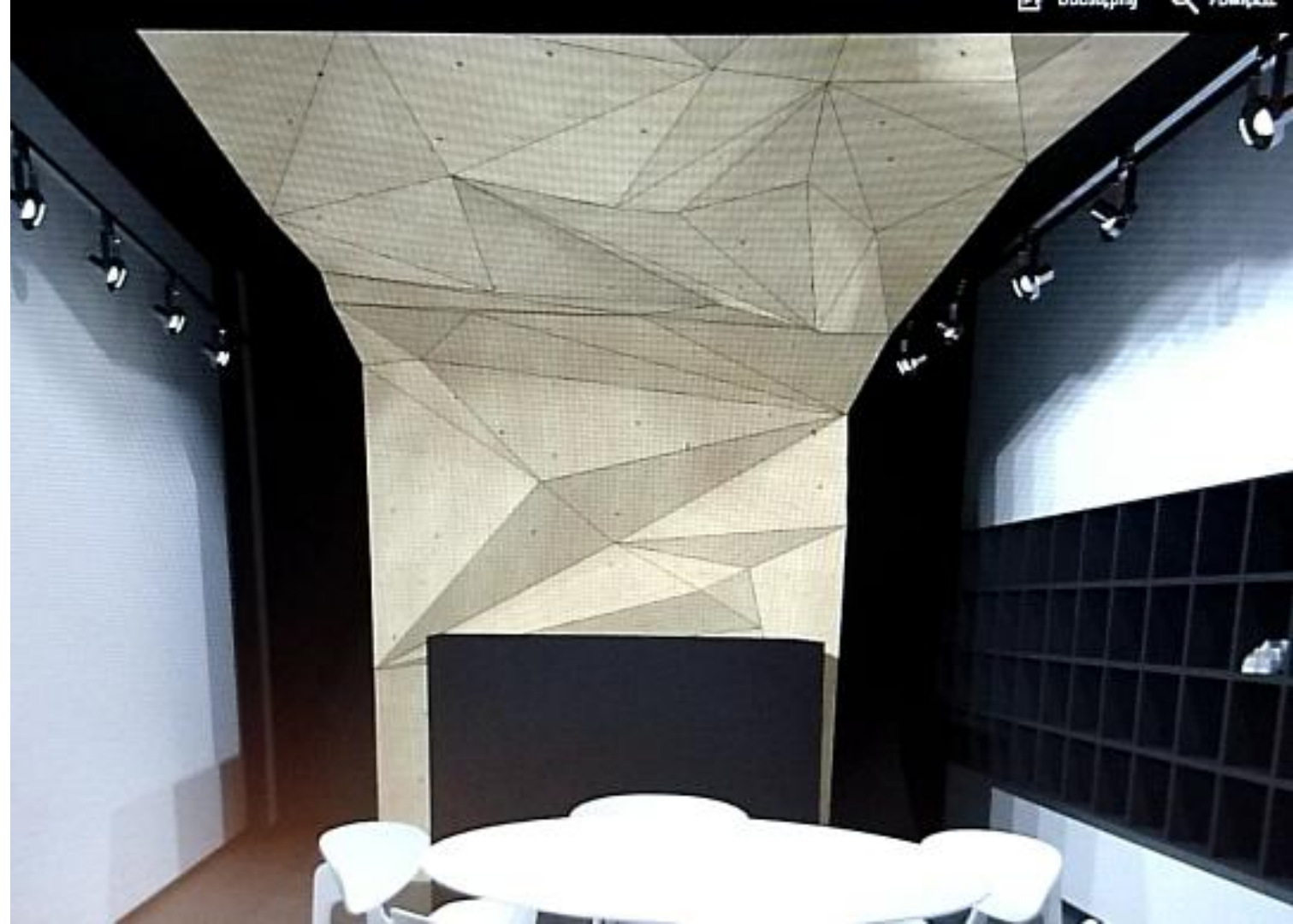

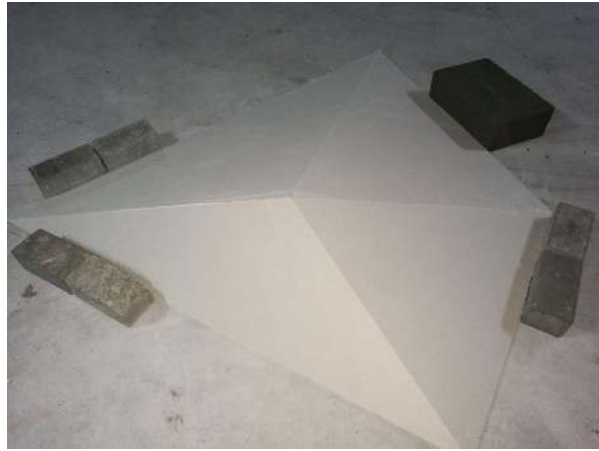





Bytom
Warszawa



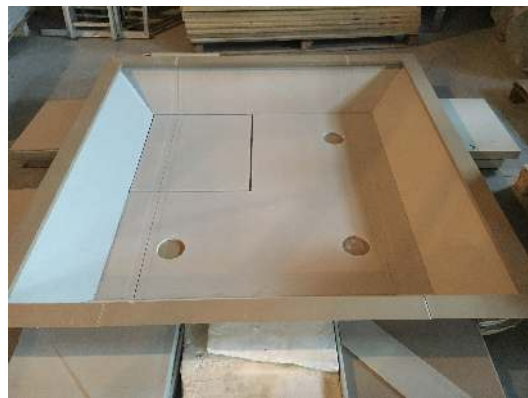

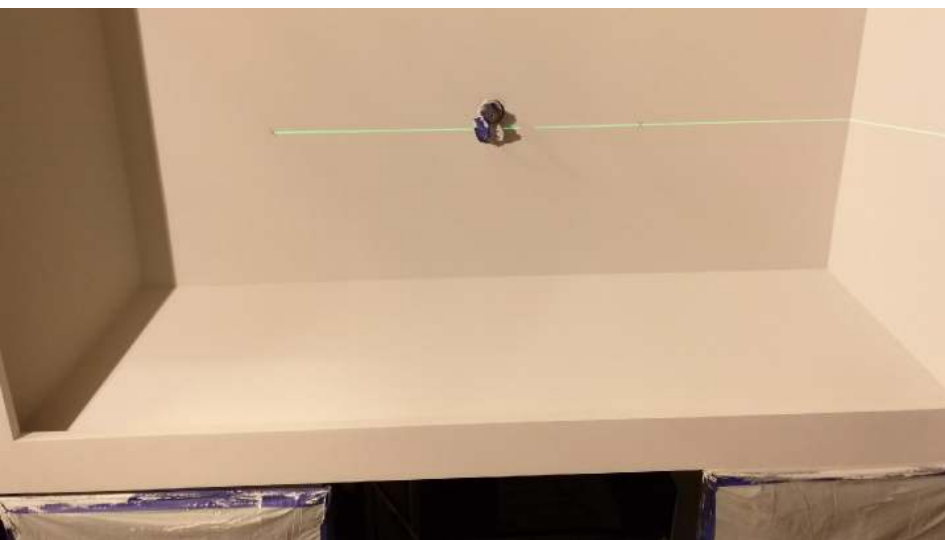





Dworzec Centralny w Warszawie



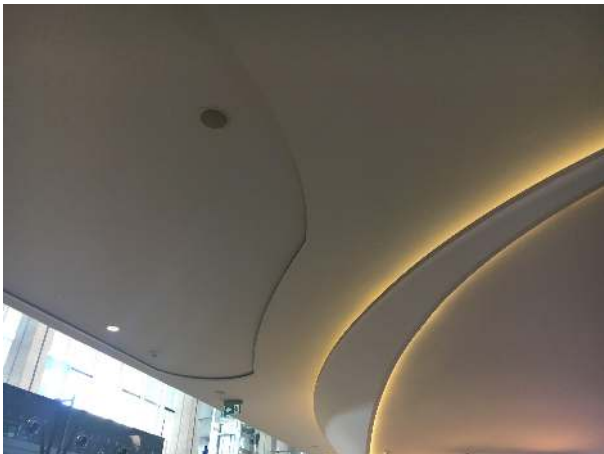
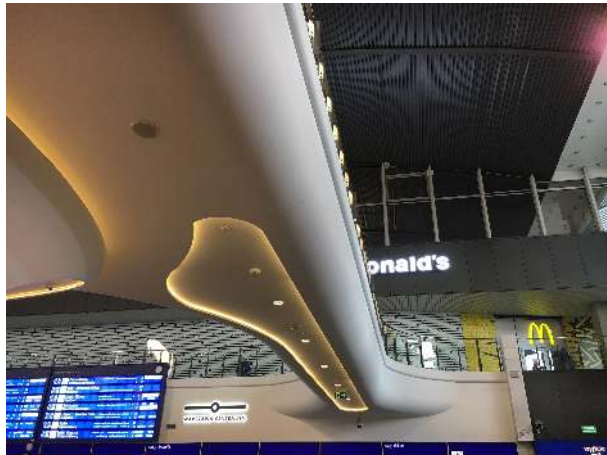

Centrum Szembeka





Hotel
SixtySix







Galeria Tomaszów







Galeria Wołomin





Obudowy słupów



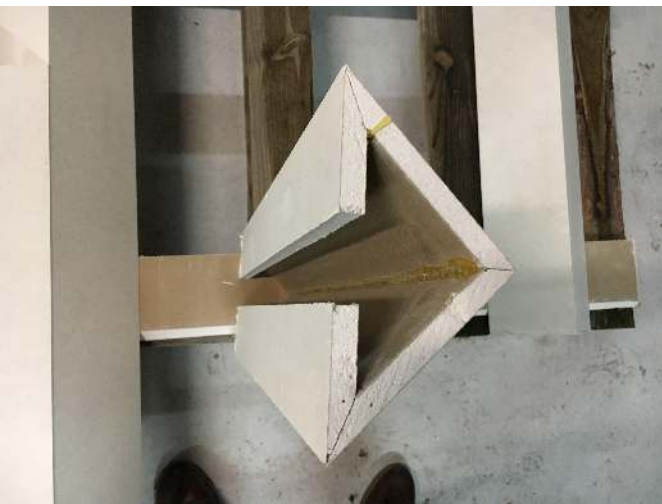



Cz 4:

Jak zamawiać?

3 Sposoby zamówień formatek:

Zamówienie pod projekt:

1. Wysyłasz do nas projekt, tak jak robili to nasi klienci w realizacjach i zastosowaniach systemu.
2. My doradzamy w kwestiach:
 - Optymalizacji produkcji
 - Sposobu montażu

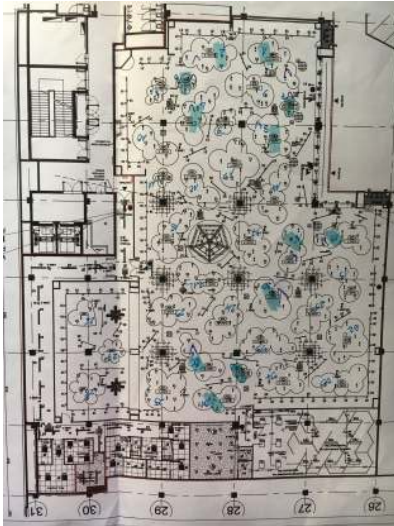

Zamówienie na podstawie formularzy zamówienia dostępnych na stronie:

<http://flexgips.com/zapytanie-o-oferte/>

Lub na podstawie odręcznych rysunków.

DANE DO ZAMÓWIENIA	
Imię i Nazwisko:	
Firma:	
Adres:	
Telefon, e-mail:	
Adres dostawy:	
Osoba do kontaktu:	
Telefon, e-mail:	
Nazwa projektu:	
Wymiary:	
A [mm]:	
B [mm]:	
C [mm]:	
D [mm]:	
Rość [mb]:	
Długość elementu:	
L = 2000 mm	
L = 3000 mm	
Rodzaj płyty	
Płyta zwykła 12,5 mm	
Płyta ognio 12,5 mm	
Płyta ognio 15 mm	
Płyta woda 12,5mm	
Uwagi:	

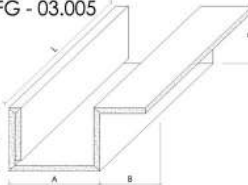

DETAL
FG - 03.005



Zamówienie standaryzowanych elementów przez sklep dostępny na stronie:

<https://sklep.flexgips.com/>

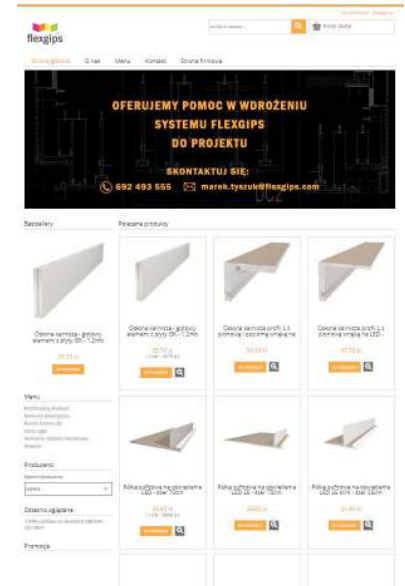
Zamówienie składa się on-line.



Cz 5:

Sklep Internetowy

Sklep z elementami o standardowych wymiarach i kształtach:



Wnęka na oświetlenie - Profil Omega

68,90 zł

do koszyka 



Oslona karnisza profil L z pionową i poziomą wnęką na

54,20 zł

do koszyka 



Półka sufitowa na oświetlenie LED 45 - szer 70cm

48,60 zł

do koszyka 



Półka sufitowa na oświetlenie LED 45 slim - szer 25cm

41,90 zł

do koszyka 



Półka sufitowa na oświetlenie LED slim - szer 25cm

38,80 zł
(1 mb = 32,33 zł)

do koszyka 



Profil "U" 150 - 1,2mb

37,30 zł

do koszyka 



Oslona karnisza z profilu U55 - gotowy element z płyty GK -

35,70 zł
(1 mb = 29,75 zł)

do koszyka 



Oslona karnisza profil L z pionową wnęką na LED -

47,70 zł

do koszyka 



Półka sufitowa na oświetlenie LED - szer 70cm

45,60 zł
(1 mb = 38,00 zł)

do koszyka 



Płyta do krzywizn - 1,2mb

42,80 zł

do koszyka 



Oslona karnisza z wnęką na oświetlenie LED - gotowy

37,20 zł
(1 mb = 31,00 zł)

do koszyka 



Profil "U" 100 - 1,2mb

35,70 zł

do koszyka 



Oslona karnisza - gotowy element z płyty GK - 1,2mb

35,70 zł
(1 mb = 29,75 zł)

do koszyka 



Uniwersalny kątownik z GK - gotowy element z płyty GK -

34,20 zł
(1 mb = 28,50 zł)

do koszyka 

1. Kątownik zwykły

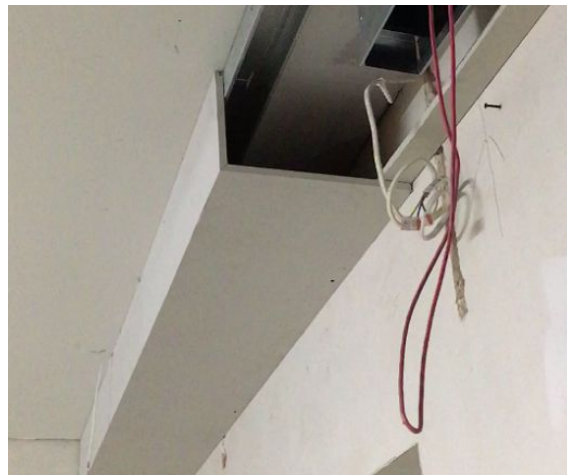

2. Ośłona karnisza



3. Półka LED zwykła

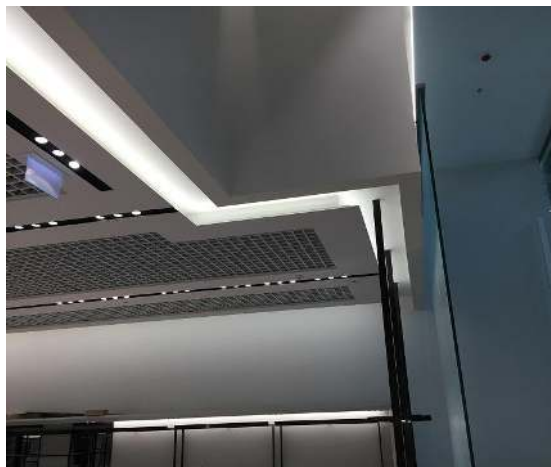

4. Półnarożnik

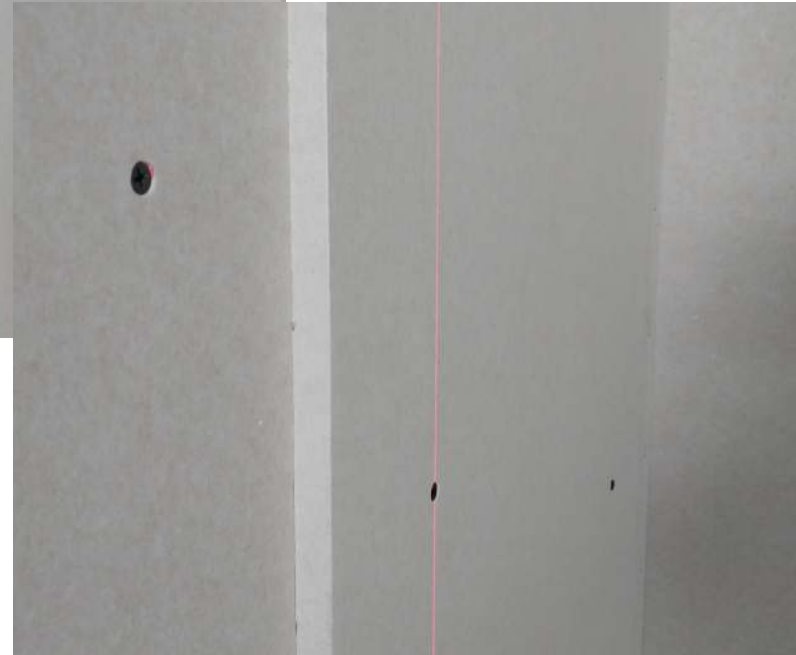
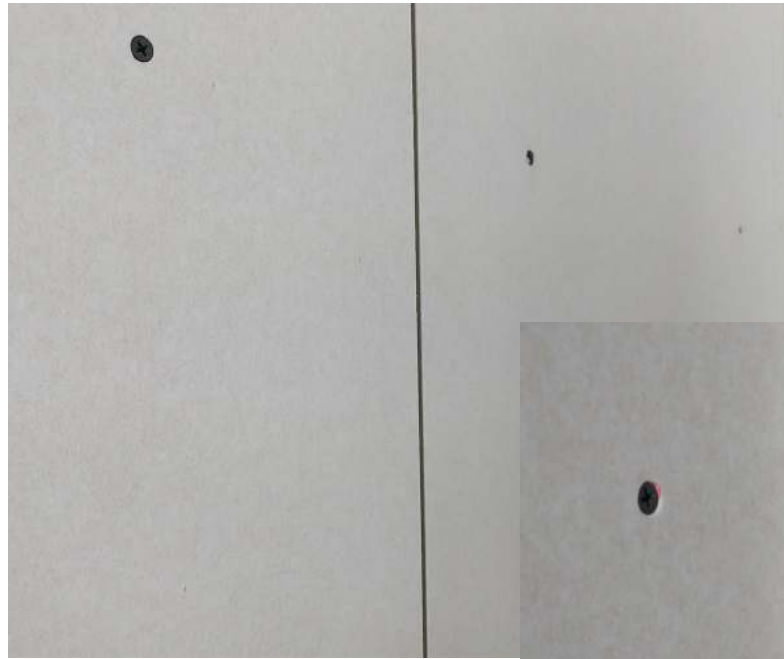

5. Profil U

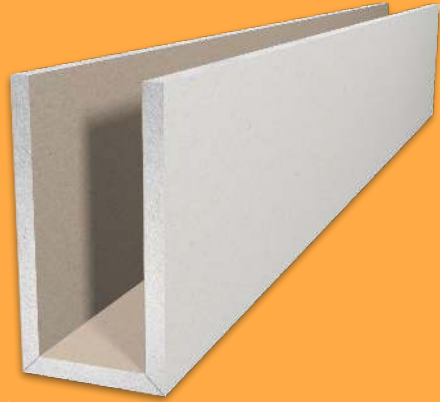

6. Płyta do krzywizn

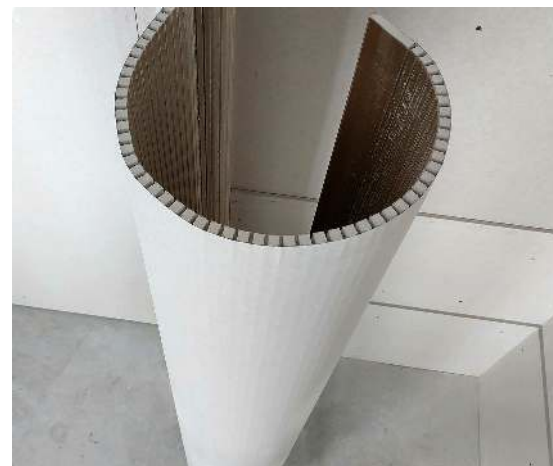
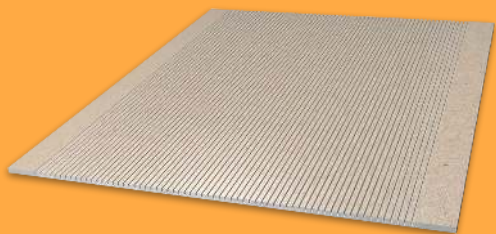



Dziękuję za poświęcony czas

Jeśli masz jakieś pytania w związku z tematem prezentacji, skontaktuj się:

Paweł Łabuda

tel.: +48 501 535 428

e-mail: p.labuda@flexgips.com

